



 GranMaster

K I T C H E N C A T A L O G U E



TABLE OF CONTENT

HISTORY	4
TECHNOLOGY	6
DESIGN DEPARTMENT	8
R&D DEPARTMENT	9
PRODUCT PROPERTIES	10
ICONS	11
COLORS	12
SINK COLOR LIST	12
PREMIUM COLLECTION	14
SERIES BIANCO	16
SERIES COMO	18
SERIES CREMONA	22
SERIES DELLO	24
SERIES FRAME	28
SERIES GRANDE	30

SERIES HORIZON	34
SERIES LAZULI	36
SERIES LUKA	40
SERIES MAGMA	44
SERIES MASSIMO	48
SERIES QUBE	50
SERIES RIVA	52
SERIES SBARRA	56
SERIES VERO	58
SERIES VICENZA	60
SERIES ZERO	62
FARMHOUSE COLLECTION	66
SERIES JULA	67
SERIES BELLA	68
SERIES EMMA	70
SERIES SBARRA	72

STANDARD COLLECTION	74
SERIES AMARETTO	76
SERIES ASTER	78
SERIES CARO	80
SERIES CELINE	82
SERIES IVO	84
SERIES GRACIA	86
SERIES QUADRATO	88
SERIES ROSA	90
SERIES SMART	92
SERIES SONNO	94
ACCESSORIES COLLECTION	96
RAILING	98
KITCHEN ORGANISER	102



HISTORY & NOW

GESCHICHTE UND JETZT / HISTOIRE ET MAINTENANT / HISTORIA Y AHORA / ИСТОРИЯ И СЕЙЧАС

EN

Wagran Sp. z o.o. was founded in 2007 in Łódź. So already has been manufacturing and selling products under the Granmaster brand for over over a dozen years. That dynamic development lead us every year from 2015 a prestigious award for well-managed and fast growing companies – BUSINESS GAZELES . We can attribute this success mainly to our customers who put their trust in us. They are the reason why we produce hundreds of thousands of products annually in more than 200 different models of sinks, sanitary facilities and metal accessories.

In 2010 on the area of 5000 m2 we have built new manufacturing facility. Then in 2017, we needed an expansion with additional warehouse and production space, as well as a state-of-the-art laboratory which allows the company to expand its offer and create top tier products.

Since then, we have been constantly expanding our team, focusing on specialists in their field. From 2018 we are strongly developing our trade and export department, due to the growing interest of customers from all over Europe and all over the World. We're receiving more and more inquiries from the most distant parts of the globe. What means for us that the quality of our products is recognized and appreciated right up there.

2019-2020 was a time when we focused on the development of our offer, which resulted in this comprehensive product catalog full of novelties. We have also expended a significant product portfolio of other branches of our activity. Now we can boast of several series of metal kitchen & bathroom accessories as well as a whole range of sanitary facilities, such as washbasins, shower trays or linear drains. We invite you to familiarize yourself also with our bathroom offer.

DE

Die Firma Wagran Sp. z o.o. ist 2007 Łódź entstanden und seit schon über ein Dutzend Jahre produziert sie und verkauft ihre Erzeugnisse unter der Marke Granmaster. Die dynamische Entwicklung der Firma brachte Früchte in Gestalt des Prestigepreises BUSINESS-GAZELLE im Jahr 2015 und in Folgejahren. Diesen Erfolg verdanken wir vor allem unseren Kunden, die uns ihr Vertrauen geschenkt haben. Für sie produzieren wir jedes Jahr Hunderttausende von Produkten in den verfügbaren 200 Spülbecken- Modellen.

2010 wurde ein neuer Produktionsbetrieb mit einer Fläche von 5000 m2 erbaut, der 2017 um eine zusätzliche Lager- und Produktionsfläche sowie um ein modernes Labor erweitert wurde, dank dem die Firma im Stande sein wird, ihr Angebot zu erweitern und Produkte von bester Qualität zu entwickeln.

Seitdem haben wir unser Team ständig erweitert und uns auf Spezialisten auf ihrem Gebiet konzentriert. Ab 2018 entwickeln wir unsere Handels- und Exportabteilung aufgrund des wachsenden Interesses von Kunden aus ganz Europa und auch aus der ganzen Welt stark weiter. Wir erhalten immer mehr Anfragen aus den entferntesten Teilen der Welt. Was bedeutet für uns, dass die Qualität unserer Produkte genau dort oben anerkannt und geschätzt wird?

Die Jahre 2019-2020 waren eine Zeit, in der wir uns stark auf die Entwicklung des Spülenangebots konzentrierten, was zu diesem umfassenden Produktkatalog voller neuer Produkte führte. Wir haben auch ein bedeutendes Produktportfolio für andere Bereiche unserer Tätigkeit entwickelt. Wir können auf mehrere Serien von Küchen- und Badzubehör aus Metall sowie auf eine ganze Reihe von Badzubehör wie Waschbecken, Duschwannen oder lineare Abflüsse verweisen. Wir laden Sie auch ein, sich mit unserem Badezimmerangebot vertraut zu machen.



FR

L'entreprise Wagrán Sp. z o.o. [sàrl] a été créée en 2007 à Łódź et depuis plus d'une douzaine d'années ans produit et vend ses produits sous la marque Granmaster. Le développement dynamique de l'entreprise s'est traduit par l'obtention d'un prix prestigieux GAZELE BIZNESU [GAZELLE DE BUSINESS] en 2015 et dans les années suivantes. Ce succès nous devons avant tout à nos clients qui ont eu confiance en nous. C'est juste pour eux que nous produisons des centaines de milliers de produits par an parmi les 200 modèles des éviers accessibles.

En 2010 a été construit le nouveaux établissement de production d'une superficie 5000 m2 lequel en 2017 avait grandi d'une superficie supplémentaire d'entrepôt et de production ainsi que le laboratoire le plus moderne, permettant à l'entreprise d'élargir son offre et de créer les produits haut de gamme.

Depuis, nous élargissons constamment notre équipe, en nous concentrant sur des spécialistes dans leur domaine. Depuis 2018, nous développons fortement notre département de commerce et d'exportation, en raison de l'intérêt croissant des clients de toute l'Europe et du monde entier. Nous recevons de plus en plus de demandes des régions les plus éloignées du globe. Ce qui signifie pour nous que la qualité de nos produits est reconnue et appréciée là-haut.

Les années 2019-2020 ont été une période pendant laquelle nous nous sommes fortement concentrés sur le développement de l'offre d'éviers, ce qui a abouti à ce catalogue complet comprenant des nouveaux produits. Nous avons également développé un portefeuille de produits important aux autres branches de notre activité. Nous pouvons nous vanter de plusieurs séries d'accessoires en métal pour la cuisine et la salle de bain ainsi que toute une gamme de produits de salle de bain : lavabos, des receveurs de douche ou des drains linéaires. Nous vous invitons également à vous familiariser avec notre offre concernant des salles de bain.

ES

La empresa Wagrán Sp. z o.o. fue creada en 2007 en Łódź e ya más de una docena de años produce y vende sus productos bajo la marca Granmaster. El desarrollo dinámico de la empresa le trajo el premio prestigioso GAZELE BIZNESU en 2015 y en los años siguientes. Este éxito se debe sobre todo a nuestros clientes que confiaron en nosotros. Son ellos para quienes producimos cientos de miles de productos al año de 200 modelos disponibles de los fregaderos.

En 2010 fue construida una nueva fábrica de la superficie de 5000 m2 que en 2017 fue complementada tanto por una superficie adicional de almacenes y de producción como por el laboratorio más moderno que posibilitará a la empresa ampliar su oferta y crear los productos de la calidad más alta.

Desde entonces, hemos ido ampliando constantemente nuestro equipo, centrándonos en especialistas en su campo. Desde 2018 estamos desarrollando fuertemente nuestro departamento de comercio y exportación, debido al creciente interés de clientes de toda Europa y también de todo el mundo. Recibimos cada vez más consultas de los lugares más distantes del mundo. Lo que significa para nosotros que la calidad de nuestros productos sea reconocida y apreciada allí mismo.

Los años 2019-2020 fueron un momento en el que nos enfocamos fuertemente en el desarrollo de la oferta de fregaderos, lo que resultó en este catálogo de productos tan complejo, lleno de nuevos productos. También hemos desarrollado una importante cartera de productos de otras ramas de nuestra actividad. Podemos presumir de varias series de accesorios metálicos de cocina y baño, y toda una gama de productos de baño: lavabos, platos de ducha o desagües lineales. También lo invitamos a familiarizarse con nuestra oferta de baño.

RUS

Компания Wagrán Sp. z o. o. была основана в 2007 году в Лодзи, лет производит и продает свои изделия под маркой Granmaster. Динамичное развитие компании привело к получению престижной премии «ГАЗЕЛИ БИЗНЕСА» в 2015 году и в последующие годы. Этим успехом мы обязаны, прежде всего, нашим клиентам, которые нам доверяют. Именно для них мы производим сотни тысяч изделий в год из 200 доступных моделей раковин.

В 2010 году был возведен новый завод площадью 5000 м2, который в 2017 году был расширен за счет дополнительных складских и производственных площадей, а также ультра-современной лаборатории, которая позволит компании расширить свое предложение и создать первоклассные изделия.

С тех пор мы постоянно расширяем нашу команду, ориентируясь на специалистов своего дела. С 2018 года мы активно развиваем наш торговый и экспортный отдел в связи с растущим интересом клиентов со всей Европы, а также со всего мира. Мы получаем все больше и больше запросов из самых отдаленных уголков земного шара. Для нас это означает, что качество нашей продукции признается и ценится прямо там.

Для нашей компании года 2019 и 2020 это время, когда мы сильно сосредоточились на развитии предложения по мойкам, что привело к созданию этого каталога с широким ассортиментом наших изделий, полного новинок. Мы также разработали портфолио продуктов по другим направлениям нашей деятельности. Мы можем похвастаться несколькими сериями металлических аксессуаров для кухни и ванных комнат, а также целым рядом сантехники для ванных комнат, таких как умывальники, душевые поддоны или линейные трапы. Мы также приглашаем вас познакомиться с нашим предложением для ванных комнат.



TECHNOLOGY

TECHNOLOGIE / TECHNOLOGIE / TECNOLOGIA / ТЕХНОЛОГИЯ

EN

The material of our composite products is a mixture of 80% of the colored quartz grains and 20% of resin connecting the grains. This recipe guarantees high resistance and freedom to choose the shape and color of the product.

Our products are characterized by:

- Antibacterial coating
- High temperature resistance
- Stain resistance
- Thermal shock resistance
- Impact resistance
- Scratch resistance.

Metal accessories are made of high-quality double-ground stainless steel. The surface of details is coated using the powder coating process.

The products are characterised by:

- Mechanical damage resistance
- Intensive surface colour (colour depth)
- Matte surface
- Scratching resistance
- Impact resistance
- Ease of maintenance

DE

Das Material für unsere Produkte ist ein Gemisch von 80% gefärbter Quarzkörnern und 20% des diese Körner verbindenden Harzes. Diese Rezeptur garantiert eine große Beständigkeit und Freiheit bei der Wahl der Produktgestalt und Farbe. Unsere Produkte zeichnen sich durch folgende

Eigenschaften aus:

- Antibakterielle Beschichtung
- Hitzebeständigkeit
- Beständigkeit gegen Entstehung von Flecken
- Temperaturschockbeständigkeit
- Stoßbeständigkeit
- Reißbeständigkeit.

Die Metalldetails sind aus hochwertigem Edelstahl der zweimal geschliffen wurde, hergestellt. Die Oberfläche der Metalldetails wurde pulverbeschichtet.

Produktmerkmale:

- Beständigkeit gegen mechanische Beschädigungen
- Intensive Farbe der Oberfläche (Farbtiefe)
- Matte Oberfläche
- Kratzfestigkeit
- Stoßfestigkeit
- Einfache Reinigung



FR

Le matériau pour nos produits est le mélange de 80% de grains de quartz coloré et de 20% de résine liant les grains. Telle composition assure la grande résistance et le libre choix de la forme et couleur du produit.

Nos produits se caractérisent par:

- Revêtement anti-bactérien
- Résistance à la température élevée
- Résistance aux taches
- Résistance au choc thermique
- Résistance aux chocs
- Résistance aux rayures.

Les accessoires métalliques sont fabriqués en acier inoxydable doublement rectifié de haute qualité. La surface des détails est recouverte par la peinture en poudre.

Caractéristiques des produits :

- Résistance aux dommages mécaniques
- Couleur intense de la surface (profondeur de couleur)
- Surface mate
- Résistance aux rayures
- Résistance aux chocs
- Facilité de nettoyage

ES

El material que usamos es una mezcla del 80% de granos de cuarzo tintado y de un 20% de resina que los une. Esta fórmula garantiza su alta resistencia y la posibilidad de elegir la forma y el color del producto.

Nuestros productos se caracterizan por:

- Una capa antiséptica
- Resistencia a altas temperaturas
- Resistencia a manchas
- Resistencia al choque térmico
- Resistencia a golpes
- Resistencia a rozaduras

Los detalles metálicos están hechos de acero inoxidable de alta calidad de doble esmerilado. La superficie de los detalles se recubre con el proceso de pintado por polvo.

Los productos se caracterizan por:

- Resistencia al daño mecánico
- Color de superficie intenso (profundidad de color)
- Superficie mate
- Resistencia al rayado
- Resistencia al impacto
- Facilidad de limpieza

RUS

Сырье для нашей продукции - это смесь, состоящая из 80% зерен окрашенного кварца и 20% смолы, соединяющего зерна. Этот рецепт гарантирует высокую стойкость и свободу выбора формы и цвета продукта.

Наши продукты характеризуются:

- Антимикробным покрытием
- Стойкостью к высокой температуре
- Устойчивостью к загрязнениям
- Термической стойкостью
- Ударопрочностью
- Стойкостью к образованию царапин.

Металлические комплектующие изготовлены из высококачественной нержавеющей стали с двойной шлифовкой. Поверхность деталей с покрытием после обработки порошковым окрашиванием.

Характеристика продукции:

- Устойчивость к механическим повреждениям
- насыщенный цвет поверхности (глубина цвета)
- Матовая поверхность
- Стойкость к царапинам
- Ударостойкость
- Легкость содержания в чистоте



DESIGN DEPARTMENT

ENTWICKLUNGSABTEILUNG / SERVICE DE DESIGN / DEPARTAMENTO DE DISEÑO / ДИЗАЙНЕРСКИЙ ОТДЕЛ

EN

Every day, our highly qualified specialists create timeless designs, functional solutions, and a wide range of products.

We have highly advanced machines and programs that enable the creation of modern projects. Our advantage is an individual approach to Customers and our business flexibility, through which we have completed more than 100 projects for new products in the past three years. The key to our success lies in the fact that we carry out the production process from developing the design through to construction of the molds and creation of a prototype. Implementation does not exceed 12 weeks.

DE

Jeden Tag kreieren erstklassige Fachleute ein zeitloses Design, funktionale Lösungen und eine breite Produktpalette. Wir verfügen über fortgeschrittene Maschinen und Programme, die es möglich machen, moderne Projekte zu entwickeln. Unser Trumpf ist die individuelle Behandlung der Kunden und die Flexibilität im Business, dank der wir über 100 Projekte neuer Erzeugnisse in den letzten 3 Jahren umgesetzt haben. Der Schlüssel zu unserem Erfolg ist die Tatsache, dass die gesamte Produktentwicklung in unserer Firma stattfindet, angefangen mit dem Entwurf, über die Formenherstellung bis hin zum Prototypbau. Der Implementierungsprozess überschreitet nicht 12 Wochen.

ES

Los profesionales calificados crean los diseños atemporales, soluciones funcionales y una amplia gama de productos. Tenemos modernas máquinas y programas que posibilitan la creación de proyectos modernos. Nuestra ventaja es el enfoque individual al cliente y la flexibilidad del negocio, gracias a lo cual hemos realizado más de 100 diseños de nuevos productos en los últimos 3 años. La clave del éxito es la implementación del producto desde el diseño por la construcción de moldes hasta la producción de prototipos en nuestra sede. El proceso de implementación no excede 12 semanas.

FR

Nos spécialistes hautement qualifiés créent chaque jour un design intemporel, des solutions fonctionnelles et une large gamme de produits. Nous possédons des machines et des logiciels ultramodernes permettant de créer des projets modernes. Nos atouts sont une approche individuelle envers le client et une grande flexibilité de notre compagnie grâce auxquels nous avons réalisé plus de 100 projets de nouveaux produits au cours des 3 dernières années. Le secret de notre succès est le fait que nous développons le produit depuis la réalisation du projet jusqu'à la fabrication des moules et jusqu'à l'élaboration du prototype. Le processus de mise en œuvre ne dépasse pas 12 semaines.

RUS

Специалисты высокого класса ежедневно создают вневременной дизайн, функциональные решения и широкий ассортимент продукции. У нас есть современное оборудование и программное обеспечение, позволяющие создавать современные проекты. Нашим преимуществом является индивидуальный подход к клиентам и деловая гибкость, благодаря чему мы реализовали свыше 100 проектов новых продуктов в течение последних трех лет. Ключ к успеху заключается в том, что мы разрабатываем продукт, начиная от дизайна, создания формы и заканчивая изготовлением прототипа в нашем офисе. Процесс внедрения не превышает 12 недель.



R&D DEPARTMENT

FORSCHUNG- UND ENTWICKLUNGSABTEILUNG / DÉPARTEMENT DE RECHERCHE ET DÉVELOPPEMENT /
DEPARTAMENTO DE INVESTIGACIÓN Y DESARROLLO / ОТДЕЛ ИССЛЕДОВАНИЯ И РАЗВИТИЯ

EN

The state-of-the-art laboratory is here to manage the whole process of production, starting with the purchase of resources to the management of the finished product. Along with the efforts of the research and development branch to provide the highest quality, it also participates in the implementation of new products and cooperates directly with the quality control branch.

All of our sinks are produced in accordance with the EN-PN 13310 norm.

DE

Die Aufgabe des modern ausgerüsteten Labors ist die Kontrolle des gesamten Produktionsprozesses vom Rohstoffwerb bis zur Prüfung der Fertigware. In der Sorge für die Höchstqualität beteiligt sich das Labor zusammen mit der Forschungs- und Entwicklungsabteilung an der Einführung neuer Produkte und arbeitet eng mit der Qualitätsabteilung zusammen.

Alle unsere Spülbecken werden gem. EN-PN 13310 hergestellt.

ES

El laboratorio moderno es responsable del control de todo el proceso de producción, desde la compra de la materias primas hasta la inspección del producto final. Junto con el departamento de investigación y desarrollo, en la búsqueda de la más alta calidad, el laboratorio participa en la aplicación de nuevos productos y coopera con el departamento de control de calidad.

Todos nuestros fregaderos se fabrican de acuerdo con la norma EN-PN 13310.

FR

Le laboratoire moderne bien équipée a pour but de contrôler tout le procès de production à partir du moment de l'achat des matières premières jusqu'au contrôle du produit fini. Avec le département des recherches et développement, en respect de la plus haute qualité, il participe à la mise en oeuvre de nouveaux produits et collabore strictement avec le département de contrôle qualité.

Tous nos éviers sont produits conformément aux dispositions de la norme EN-PN 13310.

RUS

Современно оборудованная лаборатория своей задачей имеет контроль всего процесса производства от момента закупки сырья до проверки готового изделия. Вместе с отделом исследований и развития заботясь о высоком качестве, она принимает участие во внедрении новых продуктов, а также тесно сотрудничает с отделом контроля качества.

Все наши раковины производятся в соответствии с положениями стандарта EN-PN 13310.

PRODUCT PROPERTIES

PRODUKTEIGENSCHAFTEN / PROPRIÉTÉS DU PRODUIT / PROPIEDADES DEL PRODUCTO / СВОЙСТВА ПРОДУКТА



EN - MADE IN POLAND
DE - HERGESTELLT IN POLEN
FR - FABRIQUÉ EN POLOGNE
ES - HECHO EN POLONIA
RU - ПРОИЗВЕДЕНО В ПОЛЬШЕ



EN - HYDROPHOBIC
DE - HYDROPHOBIE
FR - HYDROPHOBICITÉ
ES - HIDROFÓBICO
RU - ГИДРОФОБНОСТЬ



EN - RESISTANCE TO SUNLIGHT
DE - BESTÄNDIGKEIT GEGEN SONNENLICHT
FR - RÉSISTANCE À LA LUMIÈRE DU SOLEIL
ES - RESISTENTE A LA LUZ SOLAR
RU - УСТОЙЧИВОСТЬ К СОЛНЕЧНОМУ СВЕТУ



EN - RESISTANCE TO THERMAL SHOCK
DE - BESTÄNDIGKEIT GEGEN TEMPERATURSCHOCKS
FR - RÉSISTANCE AUX CHOCs THERMIQUES
ES - RESISTENTE AL CHOQUE TÉRMICO
RU - УСТОЙЧИВОСТЬ К ТЕРМИЧЕСКОМУ ШОКУ



EN - RESISTANCE TO HIGH TEMPERATURES
DE - BESTÄNDIGKEIT GEGEN HOHE TEMPERATUREN
FR - RÉSISTANCE AUX TEMPÉRATURES ÉLEVÉES
ES - RESISTENTE A LAS TEMPERATURAS ALTAS
RU - УСТОЙЧИВОСТЬ К ВЫСОКИМ ТЕМПЕРАТУРАМ



EN - PATENTED TECHNOLOGY
DE - PATENTIERTE TECHNOLOGIE
FR - TECHNOLOGIE BREVETÉE
ES - PATENTE TECNOLÓGICA
RU - ЗАПАТЕНТОВАННАЯ ТЕХНОЛОГИЯ

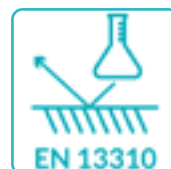

EN - RESISTANCE TO CHEMICAL AND DETERGENTS
DE - BESTÄNDIGKEIT GEGEN CHEMIKALIEN UND WASHMITTEL
FR - RÉSISTANCE AUX PRODUITS CHIMIQUES ET AUX AGENTS DE LAVAGE
ES - RESISTENTE A LAS SUSTANCIAS QUÍMICAS Y DE LAVADO
RU - УСТОЙЧИВОСТЬ К ХИМИЧЕСКИМ ВЕЩЕСТВАМ И МОЮЩИМ СРЕДСТВАМ



EN - RESISTANCE TO STAINS AND DIRT
DE - BESTÄNDIGKEIT GEGEN FLECKEN UND SCHMUTZ
FR - RÉSISTANCE AUX TACHES ET À LA SALETÉ
ES - RESISTENTE A LAS MANCHAS Y SUCIEDADES
RU - УСТОЙЧИВОСТЬ К ОБРАЗОВАНИЮ ПЯТЕН И ЗАГРЯЗНЕНИЙ



EN - RESISTANCE TO SCRATCHES
DE - KRATZFESTIGKEIT
FR - RÉSISTANCE AUX RAYURES
ES - RESISTENTE A LOS RASGUÑOS
RU - УСТОЙЧИВОСТЬ К ЦАРАПИНАМ



EN - EASY-CARE
DE - PFLEGELEICHT
FR - FACILITÉ D'ENTRETIEN
ES - CONSERVACIÓN FÁCIL
RU - ЛЕГКОСТЬ УХОДА



EN - ANTIBACTERIAL
DE - ANTIBAKTERIELL
FR - ANTIBACTÉRIEN
RU - АНТИБАКТЕРИАЛЬНЫЙ



EN - 100% NEUTRAL IN CONTACT WITH FOOD
DE - 100% LEBENSMITTELNEUTRAL
FR - 100% NEUTRE EN CONTACT AVEC LES ALIMENTS
ES - 100% NEUTRAL EN CONTACTO CON ALIMENTOS
RU - 100% НЕЙТРАЛЬНЫЙ ПРИ КОНТАКТЕ С ПИЩЕВЫМИ ПРОДУКТАМИ

ICONS

SYMBOLE / ICÔNES / ICONOS / ИКОНКИ



EN - REVERSIBLE
DE - WENDESPÜLE
FR - RÉVERSIBLE
ES - SE PUEDE VOLTEAR
RU - ОБРАТИМЫЯ МОЙКА

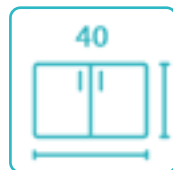

EN - CABINET DIMENSION
DE - SCHRANKABMESSUNGEN
FR - DIMENSIONS DE LAPETITE
ES - DIMENSIONES DEL ARMARIO
RU - РАЗМЕРЫ ШКАФЧИКА



EN - SIPHON INCLUDED
DE - SIPHON IM SET
FR - SIPHON INCLU
ES - SIFÓN ADJUNTO
RU - СИФОН В КОМПЛЕКТЕ



EN - WOODEN BOARDS
DE - HOLZBRETT
FR - DES PLANCHES EN BOIS
ES - TABLAS DE MADERA
RU - ДЕРЕВЯННЫЕ ДОСКИ

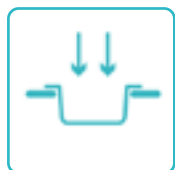

EN - TOP MOUNTED
DE - EINBAUSPÜLEN / KLASSISCH
FR - AU DESSUS DU PLATEAU
ES - MONTAJE SUPERIOR
RU - НАД СТОЛЕШНИЦЕЙ



EN - UNDER MOUNTED
DE - UNTERBAU
FR - SOUS PLATEAU
ES - MONTAJE BAJO
RU - ПОД СТОЛЕШНИЦЕЙ



EN - FLUSH MOUNTED
DE - FLÄCHENBÜNDIG
FR - AU NIVEAU DU PLATEAU
ES - MONTAJE EMPOTRADO
RU - ВУРОВЕНЬ СТОЛЕШНИЦЫ



EN - METAL ACCESSORIES
DE - ZUBEHÖR AUS METALL
FR - ACCESSOIRES EN MÉTAL
ES - ACCESORIOS DE METAL
RU - МЕТАЛЛИЧЕСКИЕ АКСЕССУАРЫ

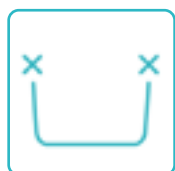

EN - WITHOUT DRAINER
DE - OHNE ABTROPFFLÄCHE
FR - SANS ÉGOUTTOIR
ES - SIN ESCURRIDOR
RU - БЕЗ КРЫЛА ДЛЯ СУШКИ



EN - STANDARD DRAINER
DE - STANDARDGESCHIRRABTROPFER
FR - EGOUTTOIR STANDARD
ES - ESTÁNDAR
RU - СТАНДАРТНОЕ КРЫЛО ДЛЯ СУШКИ ПОСУДЫ



EN - TWO-SIDED DRAINER
DE - ZWEISEITIGER GESCHIRRABTROPFER
FR - EGOUTTOIR BILATERAL
ES - ESCURRIDOR DOBLE
RU - ДВУСТОРОННЕЕ КРЫЛО



EN - NO REVERSIBLE
DE - NICHT WENDESPÜLE
FR - IRRÉVERSIBLE
ES - NO SE PUEDE VOLTEAR
RU - НЕОБРАТИМЫЯ МОЙКА



EN - 1 BOWL
DE - EIN-KAMMER SPÜLBECKEN
FR - 1 COMPARTIMENT
ES - 1 CÁMARA
RU - 1 СЕКЦИОННАЯ



EN - 1.5 BOWL
DE - EINEINHALB KAMMER SPÜLBECKEN
FR - 1,5 COMPARTIMENT
ES - 1,5 CÁMARA
RU - 1,5 СЕКЦИОННАЯ



EN - 2 BOWLS
DE - ZWEI-KAMMER SPÜLBECKEN
FR - 2 COMPARTIMENTS
ES - 2 CÁMARA
RU - 2 СЕКЦИОННАЯ

COLORS

FARBEN / COULEURS / COLOR / ЦВЕТА



1
EN - SAFARI
DE - SAFARI
FR - SAFARI
ES - SAFARI
RU - САФАРИ

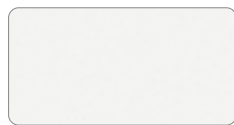

A
EN - WHITE
DE - WEISS
FR - BLANC
ES - BLANCO
RU - БЕЛЫЙ

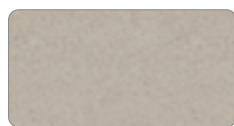

7
EN - SAND
DE - SANDGELB
FR - SABLE
ES - ARENA
RU - ПЕСОЧНЫЙ

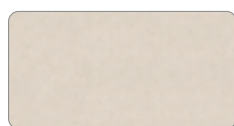

P
EN - LIGHT BEIGE
DE - HELLBEIGE
FR - BEIGE CLAIR
ES - BEIGE CLARO
RU - СВЕТЛО-БЕЖЕВЫЙ



2
EN - GRAPHITE
DE - GRAFITGRAU
FR - GRAPHITE
ES - GRAFITO
RU - ГРАФИТ

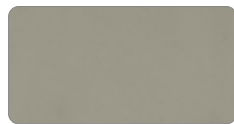

F
EN - TRUFFLE
DE - TRÜFFEL
FR - TRUFFE
ES - TRUFA
RU - ТРЮФЕЛЬ

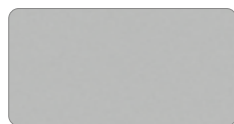

S
EN - GREY METALLIC
FR - GRIS METALLIQUE
ES - GRIS METÁLICO
DE - GRAU METALLIC
RU - СЕРЫЙМЕТАЛЛИК



N
EN - BLACK MATT (DEEP BLACK)
DE - SCHWARZ MATT (TIEF SCHWARZ)
FR - NOIR MAT (NOIR PROFOND)
ES - NEGRO MATE (NEGRO PROFUNDO)
RU - ЧЕРНЫЙ МАТОВЫЙ (ГЛУБОКИЙ ЧЕРНЫЙ)



G
EN - BLACK METALLIC
DE - SCHWARZ METALLIC
FR - NOIR METALLIQUE
ES - NEGRO METÁLICO
RU - ЧЕРНЫЙ МЕТАЛЛИК



D
EN - TITAN
DE - TITAN
FR - TITAN
ES - TITÁN
RU - ТИТАН



M
EN - MOCCA
DE - MOCCA
FR - MOCCA
ES - MOCCA
RU - МОККА

SINK COLOR LIST

STANDARD COLLECTION

SERIES	7	P	1	2
AMARETTO				
ASTER				
CARO				
CELINE				
IVO				
GRACIA				
QUADRATO				
ROSA				
SMART				
SONNO				

PREMIUM COLLECTION

SERIES	P	A	F	S	D	M	G	N
BIANCO								
COMO								
CREMONA								
DELLO								
FRAME								
GRANDE								
HORIZON								
LAZULI								
LUKA								
MAGMA								
MASSIMO								

SERIES	P	A	F	S	D	M	G	N
QUBE								
RIVA								
SBARRA								
VERO								
VICENZA								
ZERO								

FARMHOUSE COLLECTION

SERIES	P	A	F	S	D	M	G	N
JULA								
BELLA								
EMMA								
SBARRA								

PREMIUM COLLECTION





SERIES **BIANCO**

ZYB_X10B (G)

SINK DIMENSIONS: 790x510x216mm
BOWL DIMENSIONS: 440x430x200mm
270x385x115mm

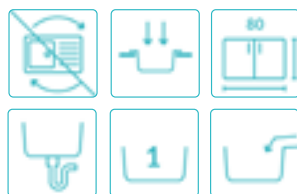
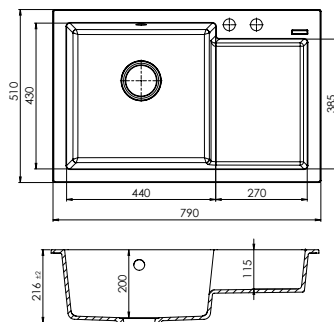

ZYB_X203 (F)

SINK DIMENSIONS: 790x510x214mm
BOWL DIMENSIONS: 390x430x200mm
287x380x200mm

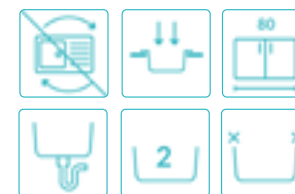
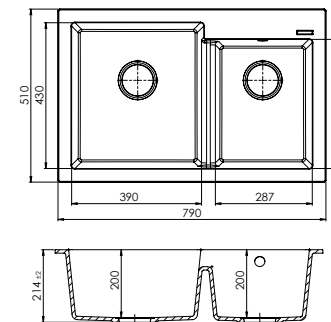



SERIES **COMO**

ZYO_X10A

SINK DIMENSIONS:
210x440x142mm

BOWL DIMENSIONS:
170x400x130mm

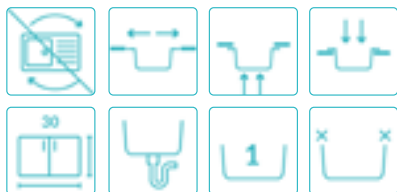
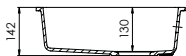
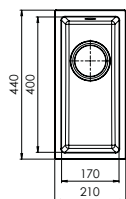

ZYO_X10B

SINK DIMENSIONS:
380x440x200mm

BOWL DIMENSIONS:
340x400x188mm

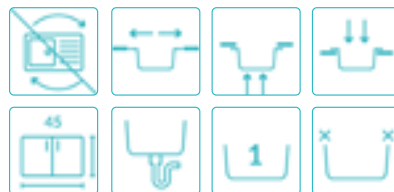
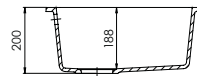
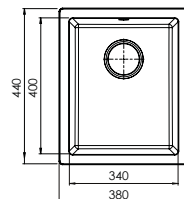

ZYO_X10C

SINK DIMENSIONS:
540x440x200mm

BOWL DIMENSIONS:
500x400x188mm

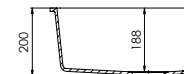
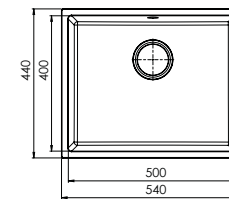

ZYO_X10D

SINK DIMENSIONS:
590x440x200mm

BOWL DIMENSIONS:
550x400x188mm

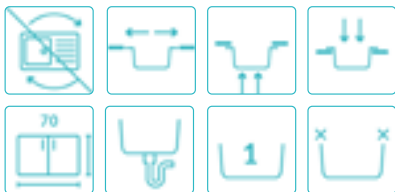
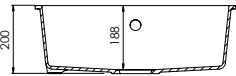
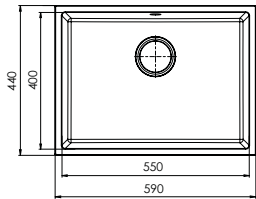

ZYO_X10E

SINK DIMENSIONS:
780x440x200mm

BOWL DIMENSIONS:
740x400x188mm

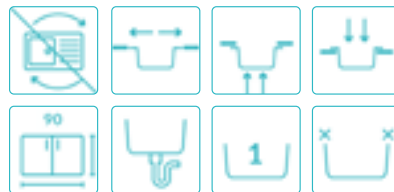
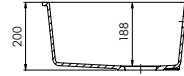
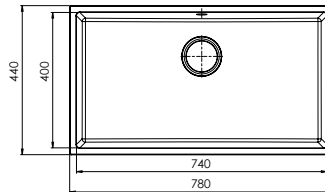

ZYO_X40B

SINK DIMENSIONS:
440x440x202mm

BOWL DIMENSIONS:
400x400x188mm

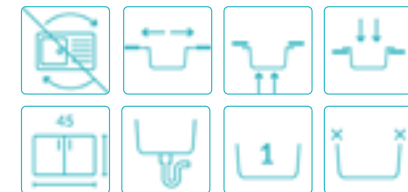
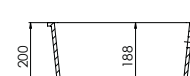
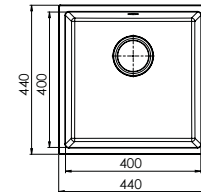

ZYO_X50D

SINK DIMENSIONS:
558x460x213mm

BOWL DIMENSIONS:
310x410x200mm
160x410x130mm

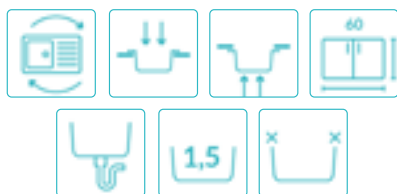
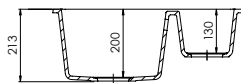
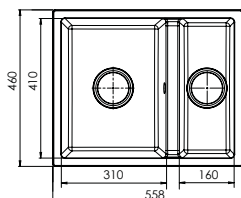



SERIES **CREMONA**

CREMONA

ZTC_X1F3(F)

SINK DIMENSIONS:
410x510x222mm

BOWL DIMENSIONS:
350x405x205mm

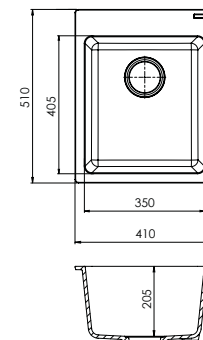

ZTC_X2F3(F)

SINK DIMENSIONS:
860x510x222mm

BOWL DIMENSIONS:
385x405x205mm
385x405x205mm

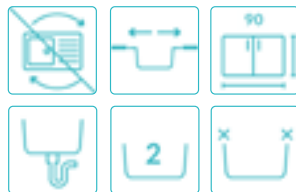
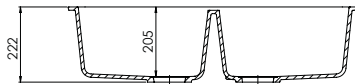
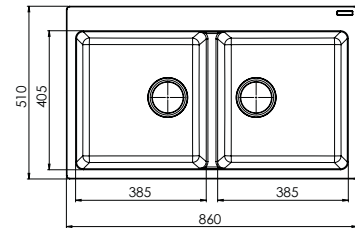

ZTC_X4F3(F)

SINK DIMENSIONS:
600x510x222mm

BOWL DIMENSIONS:
540x405x205mm

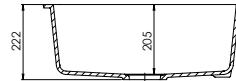
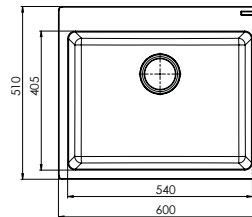

ZTC_X7F3(F)

SINK DIMENSIONS:
760x510x222mm

BOWL DIMENSIONS:
700x405x205mm

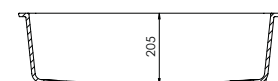
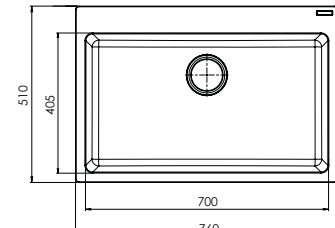



SERIES **DELLO**

ZYE_X11A (E)

SINK DIMENSIONS:
790x500x210mm

BOWL DIMENSIONS:
400x440x196mm

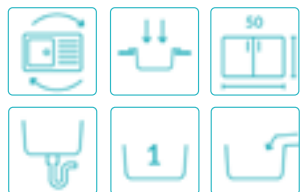
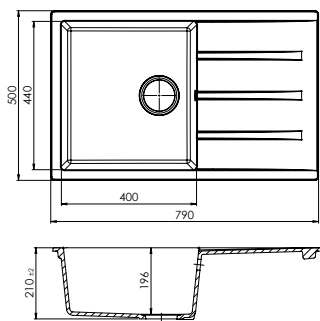

ZYE_X113 (F)

SINK DIMENSIONS:
860x500x210mm

BOWL DIMENSIONS:
430x440x196mm

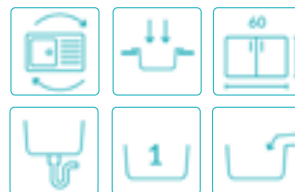
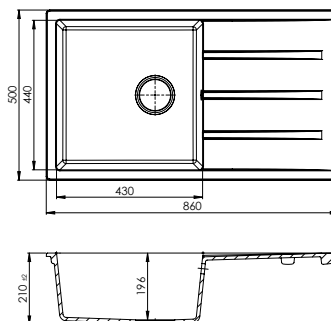

ZYE_X713 (F)

SINK DIMENSIONS:
1000x500x210mm

BOWL DIMENSIONS:
500x440x196mm

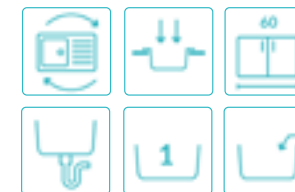
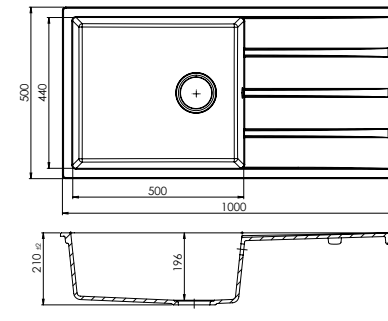

ZYE_X213 (F)

SINK DIMENSIONS:
1160x500x210mm

BOWL DIMENSIONS:
335x440x196mm
335x440x196mm

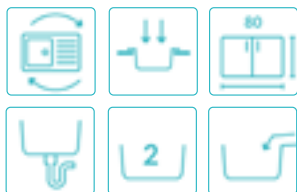
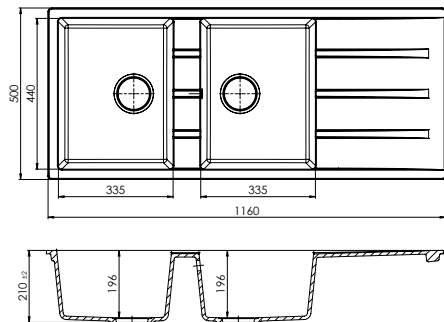

ZYE_X513 (F)

SINK DIMENSIONS:
1000x500x212mm

BOWL DIMENSIONS:
354x440x197mm
160x348x147mm

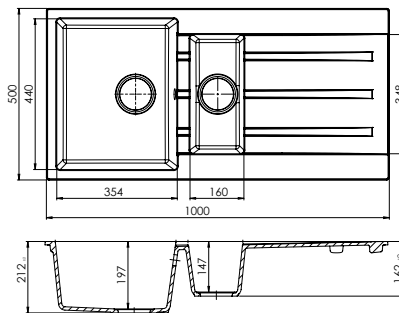





SERIES **FRAME**

ZYS_X11A (E)

SINK DIMENSIONS:
860x500x203mm

BOWL DIMENSIONS:
480x450x190mm

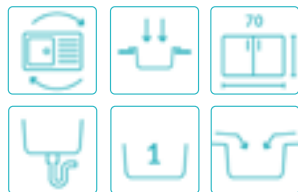
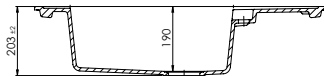
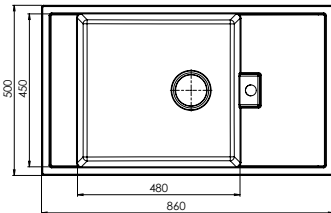

ZYS_X71A (E)

SINK DIMENSIONS:
860x500x206mm

BOWL DIMENSIONS:
550x450x190mm

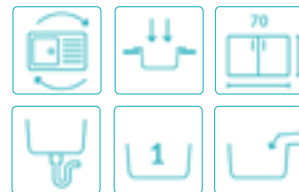
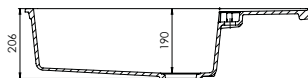
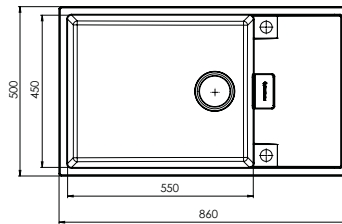

ZYS_X113 (F)

SINK DIMENSIONS:
780x500x194mm

BOWL DIMENSIONS:
350x450x180mm

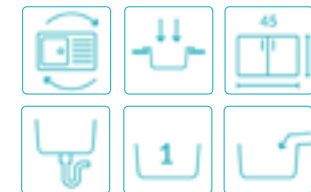
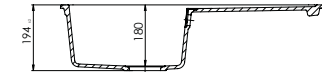
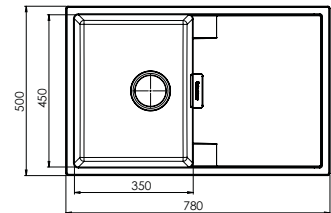



SERIES **GRANDE**

ZYD_X71A (E)

SINK DIMENSIONS:
860x500x193mm

BOWL DIMENSIONS:
600x355x180mm

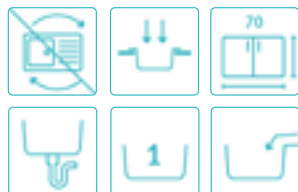
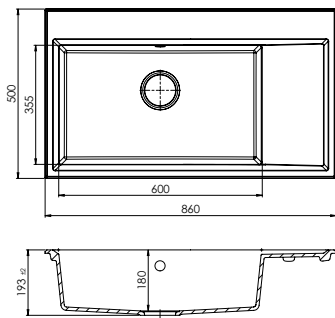

ZYD_X703 (F)

SINK DIMENSIONS:
790x500x193mm

BOWL DIMENSIONS:
710x355x180mm

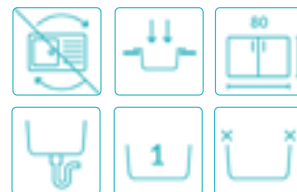
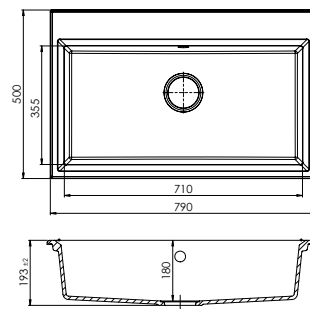

ZYD_X70D (H)

SINK DIMENSIONS:
838x559x242mm

BOWL DIMENSIONS:
762x415x229mm

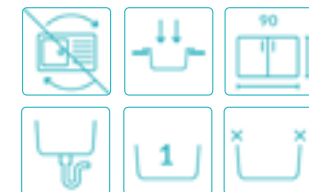
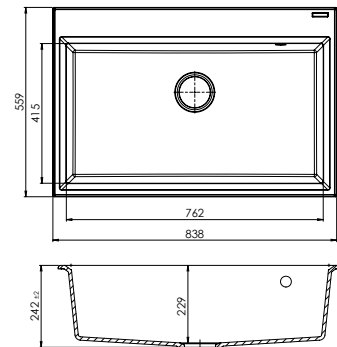

ZYD_X10B (G)

SINK DIMENSIONS:
610x500x193mm

BOWL DIMENSIONS:
538x365x180mm

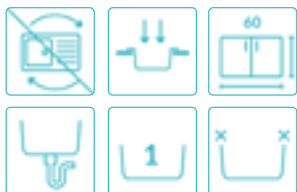
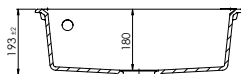
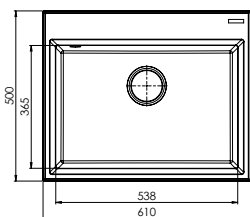

ZYD_X103 (F)

SINK DIMENSIONS:
500x580x194mm

BOWL DIMENSIONS:
430x445x180mm

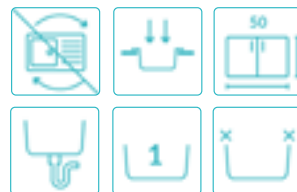
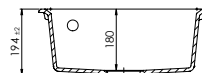
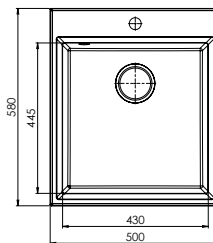

ZYD_X203 (F)

SINK DIMENSIONS:
838x559x243mm

BOWL DIMENSIONS:
362x415x229mm
362x415x229mm

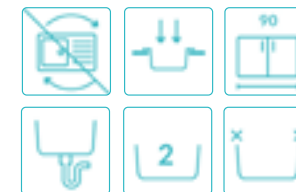
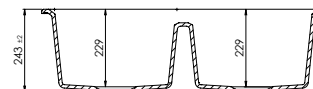
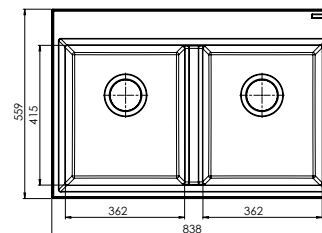





SERIES **HORIZON**

ZVH_X11A (E)

SINK DIMENSIONS:
650x500x203mm

BOWL DIMENSIONS:
380x440x190mm

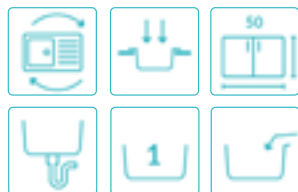
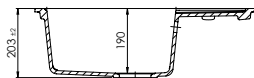
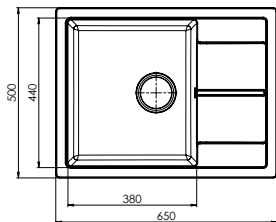

ZVH_X71A (E)

SINK DIMENSIONS:
780x500x203mm

BOWL DIMENSIONS:
480x440x190mm

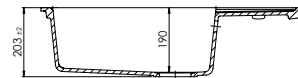
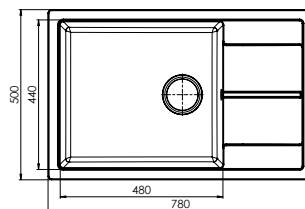

ZVH_X113 (F)

SINK DIMENSIONS:
780x500x201mm

BOWL DIMENSIONS:
400x440x185mm

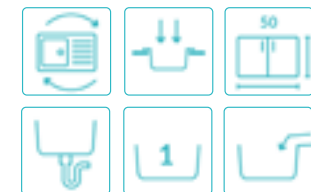
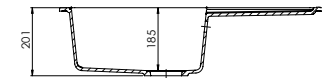
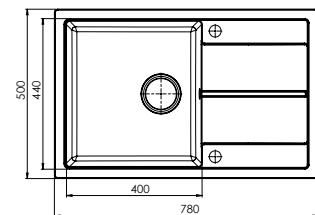



SERIES **LAZULI**

ZYL_X113 (F)

SINK DIMENSIONS:
860x500x193mm

BOWL DIMENSIONS:
400x410x180mm

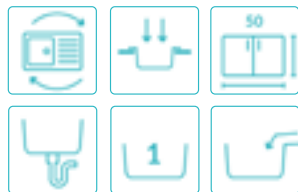
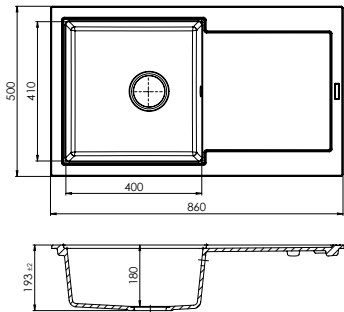

ZYL_X513 (F)

SINK DIMENSIONS:
860x500x192mm

BOWL DIMENSIONS:
342x370x180mm
187x370x180mm

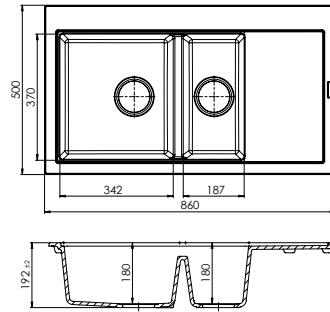

ZYL_X203 (F)

SINK DIMENSIONS:
860x500x193mm

BOWL DIMENSIONS:
400x410x180mm
335x370x180mm

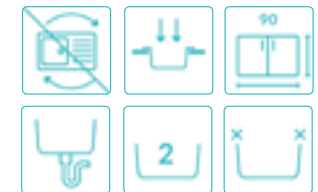
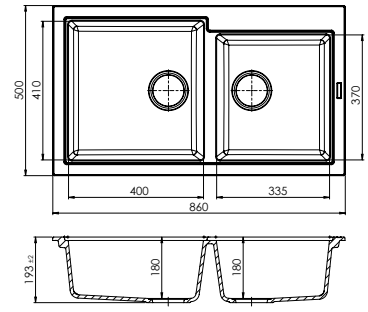

ZYL_X713 (F)

SINK DIMENSIONS:
970x500x204mm

BOWL DIMENSIONS:
410x450x180mm

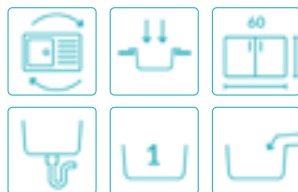
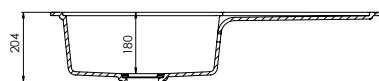
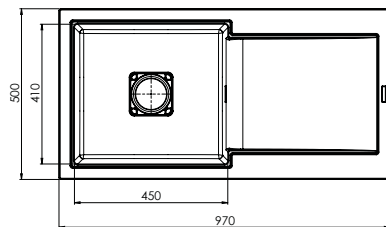

ZYL_X813 (F)

SINK DIMENSIONS:
1000x500x204mm

BOWL DIMENSIONS:
410x380x180mm
160x350x120mm

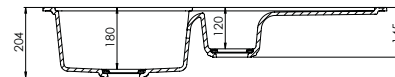
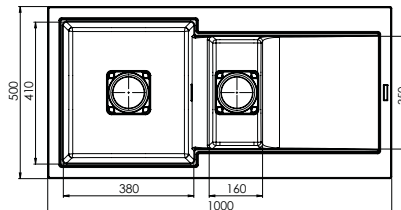





SERIES **LUKA**

ZYK_X11A (E)

SINK DIMENSIONS:
640x500x184mm

BOWL DIMENSIONS:
319x419x170mm

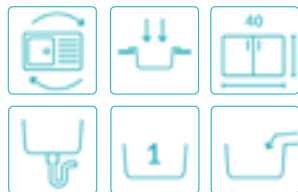
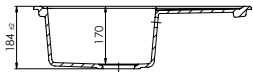
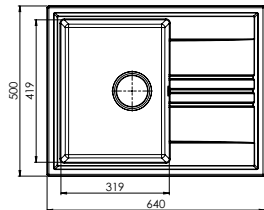

ZYK_X113 (F)

SINK DIMENSIONS:
860x500x184mm

BOWL DIMENSIONS:
359x419x170mm

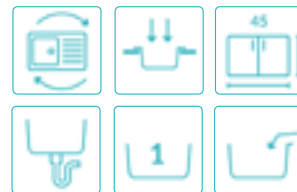
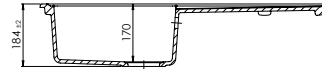
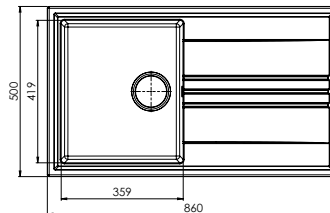

ZYK_X213 (F)

SINK DIMENSIONS:
1160x500x184mm

BOWL DIMENSIONS:
335x420x170mm
335x420x170mm

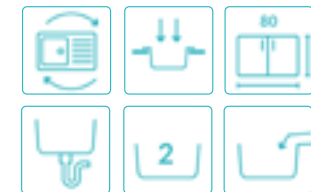
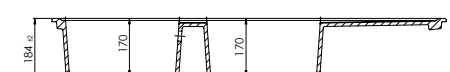
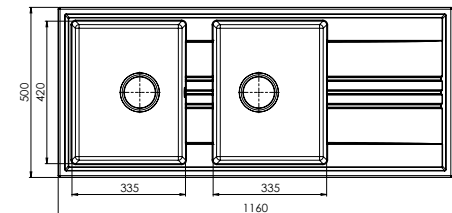

ZYK_X513 (F)

SINK DIMENSIONS:
960x500x184mm

BOWL DIMENSIONS:
340x420x170mm
160x300x130mm

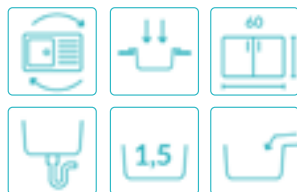
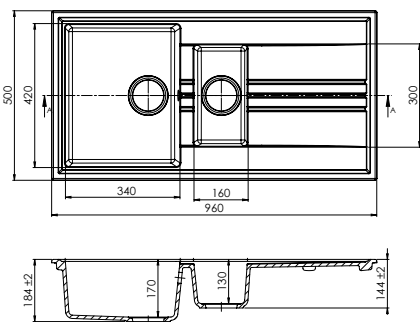

ZYK_X713 (F)

SINK DIMENSIONS:
1000x500x184mm

BOWL DIMENSIONS:
500x420x170mm

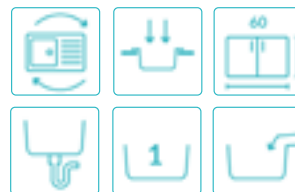
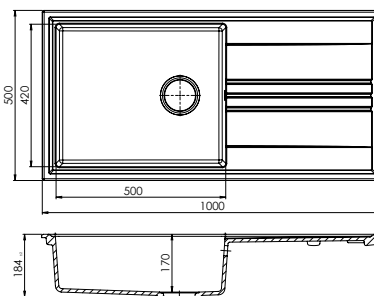

ZYK_X71A (E)

SINK DIMENSIONS:
590x500x219mm

BOWL DIMENSIONS:
340x420x205mm

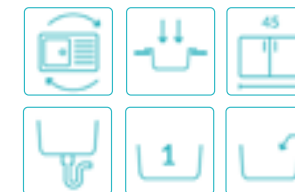
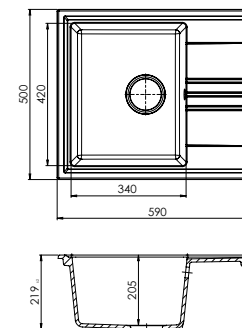





SERIES **MAGMA**

SLM_X10T (F)

SINK DIMENSIONS:
530x500x204mm

BOWL DIMENSIONS:
490x380x190mm

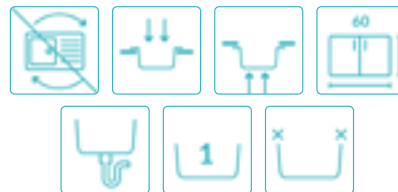
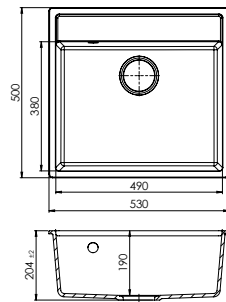

SLM_X10A (E)

SINK DIMENSIONS:
440x520x204mm

BOWL DIMENSIONS:
400x400x190mm

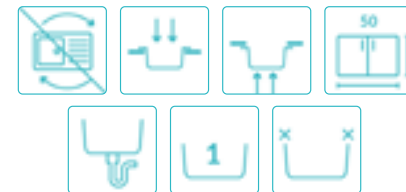
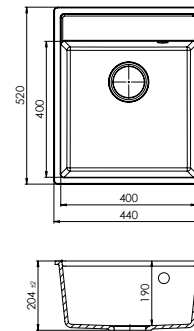

SLM_X40A (E)

SINK DIMENSIONS:
540x520x204mm

BOWL DIMENSIONS:
500x400x190mm

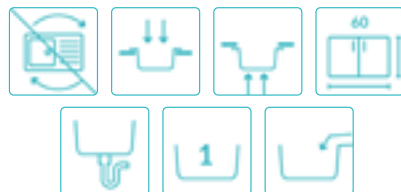
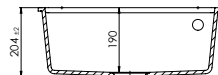
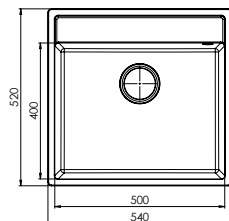

SLM_X70A (E)

SINK DIMENSIONS:
640x520x204mm

BOWL DIMENSIONS:
600x400x190mm

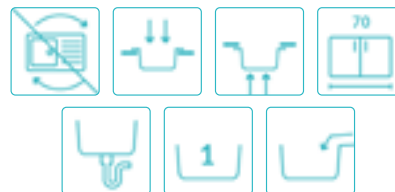
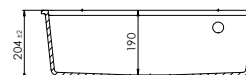
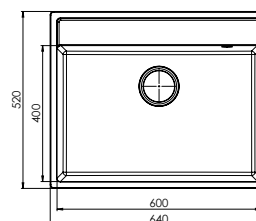





SERIES MASSIMO

ZYM_X103 (F)

SINK DIMENSIONS:
560x480x203mm

BOWL DIMENSIONS:
515x385x190mm

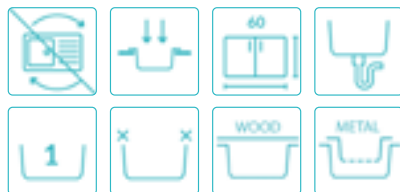
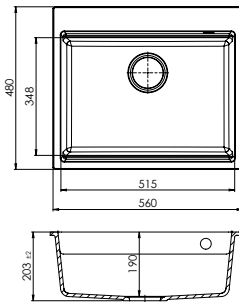

ZYM_X503 (F)

SINK DIMENSIONS:
760x480x203mm

BOWL DIMENSIONS:
509x380x190mm
187x380x190mm

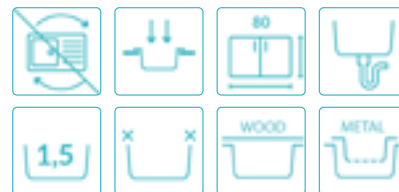
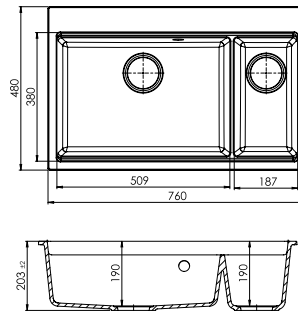

ZZSXX06A MASSIMO TRAY

DIMENSIONS:
430x183x19mm

MATERIAL:
stainless steel

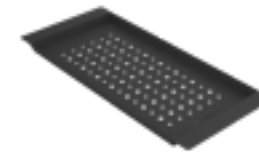

BLACK

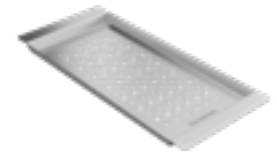

INOX

ZZSXX04A PLATE TRAY

DIMENSIONS:
366x176x63mm

MATERIAL:
stainless steel



BLACK



INOX

ZZB_X01A BOARD

DIMENSIONS:
402x214x15mm

MATERIAL:
beech wood



NATURAL WOOD



SERIES **QUBE**

QUBE

ZVQ_X10T (F)

SINK DIMENSIONS:
530x500x209mm

BOWL DIMENSIONS:
490x370x194mm

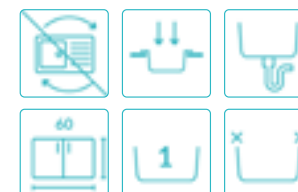
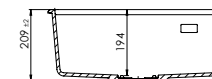
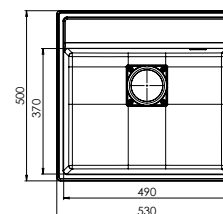

ZVQ_X713 (F)

SINK DIMENSIONS: 860x500x201mm
BOWL DIMENSIONS: 530x420x180mm

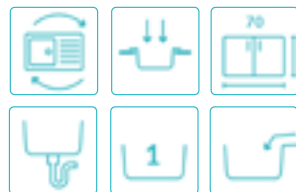
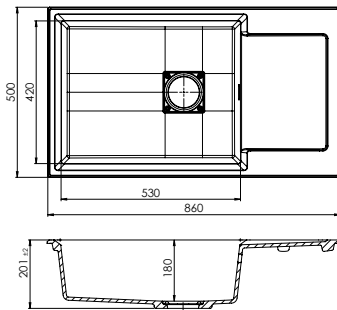

ZVQ_X10D (H)

SINK DIMENSIONS: 610x500x202mm
BOWL DIMENSIONS: 538x425x180mm

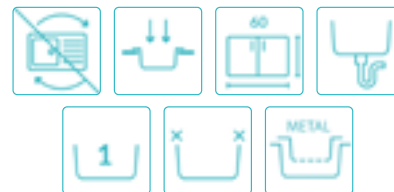
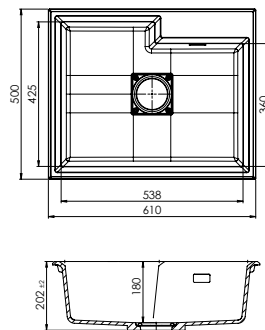

ZZPXX07A BASKET TO SINK

DIMENSIONS: 272x105x68mm
MATERIAL: stainless steel



BLACK

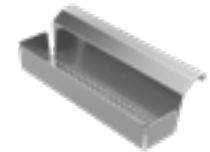

INOX





SERIES **RIVA**

ZYV_X113 (F)

SINK DIMENSIONS:
860x500x210mm

BOWL DIMENSIONS:
430x440x196mm

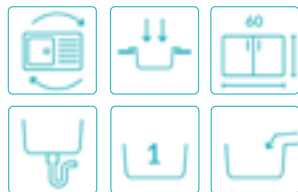
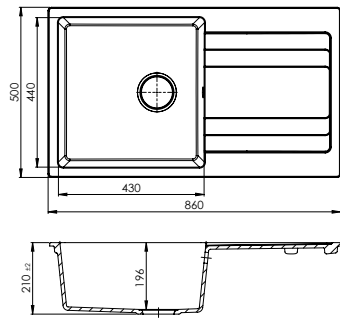

ZYV_X213 (F)

SINK DIMENSIONS:
1160x500x210mm

BOWL DIMENSIONS:
335x440x196mm
334x440x196 mm

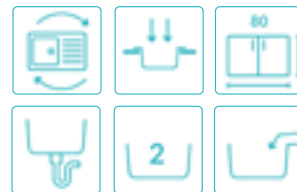
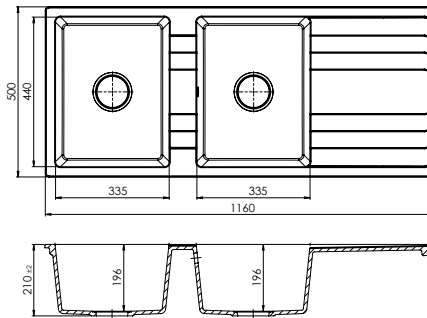

ZYV_X513 (F)

SINK DIMENSIONS:
960x500x209mm

BOWL DIMENSIONS:
430x440x196mm
170x350x130mm

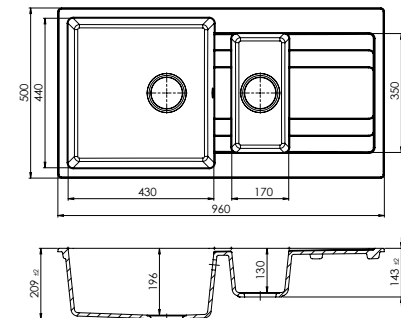

ZYV_X713 (F)

SINK DIMENSIONS: 1000x500x210mm
BOWL DIMENSIONS: 500x440x196mm

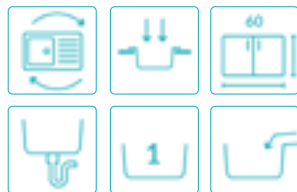
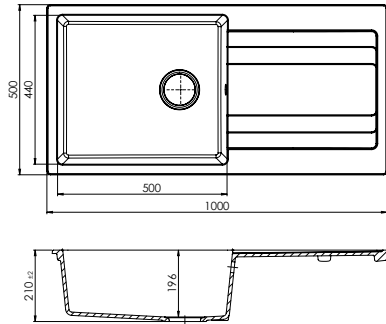

ZYV_X813 (F)

SINK DIMENSIONS: 1000x500x206mm
BOWL DIMENSIONS: 340x420x196mm
 160x350x120mm

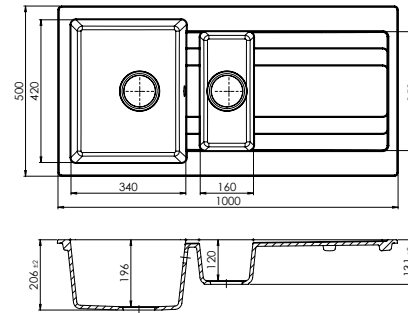

ZYV_X913 (F)

SINK DIMENSIONS: 1160x500x208mm
BOWL DIMENSIONS: 440x440x196mm
 270x355x170mm

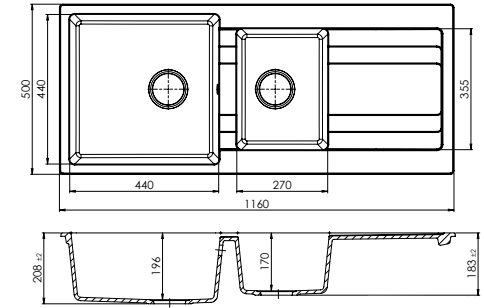





SERIES SBARRA

ZVZ_X10B

SINK DIMENSIONS:
560x482x249mm

BOWL DIMENSIONS:
492x415x234mm

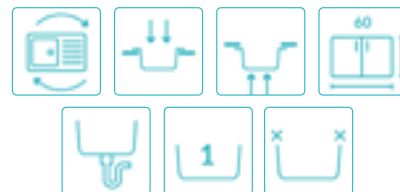
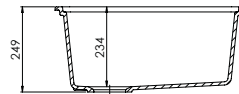
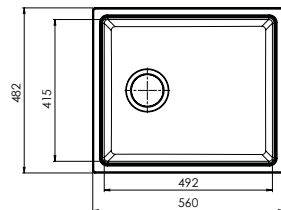

ZVZ_X10C

SINK DIMENSIONS:
760x482x249mm

BOWL DIMENSIONS:
692x415x234mm

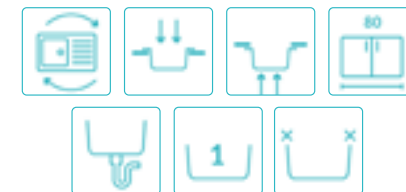
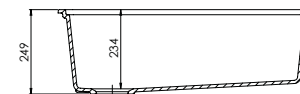
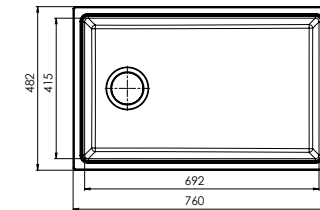



SERIES **VERO**

ZVV_X113 (F)

SINK DIMENSIONS: 970x500x204mm
BOWL DIMENSIONS: 460x430x190mm

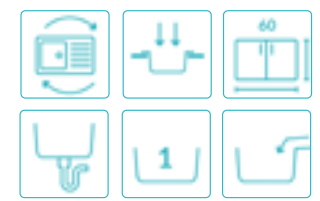
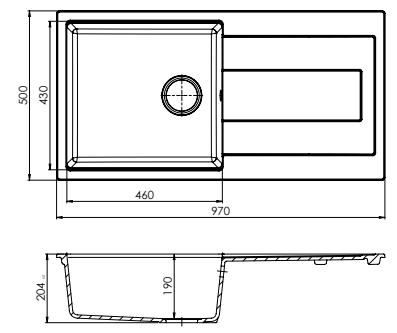

ZVV_X513 (F)

SINK DIMENSIONS: 970x500x204mm
BOWL DIMENSIONS: 350x430x190mm
160x350x130mm

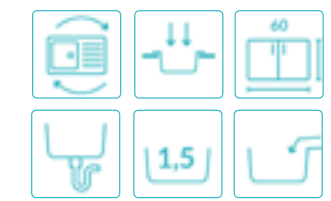
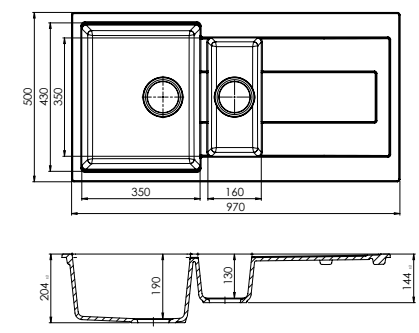



SERIES **VICENZA**



VICENZA

ZVI_X113

SINK DIMENSIONS:
970x500x209mm

BOWL DIMENSIONS:
450x450x180mm

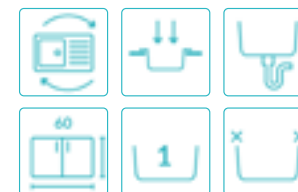
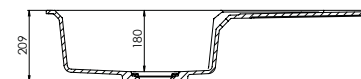
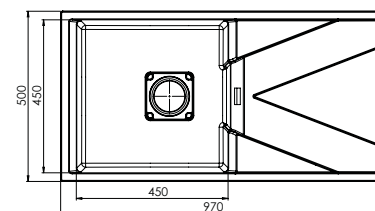



SERIES **ZERO**

ZYZ_X71A (A)

SINK DIMENSIONS: 1160x520x213mm
 BOWL DIMENSIONS: 700x385x200mm

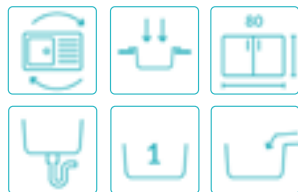
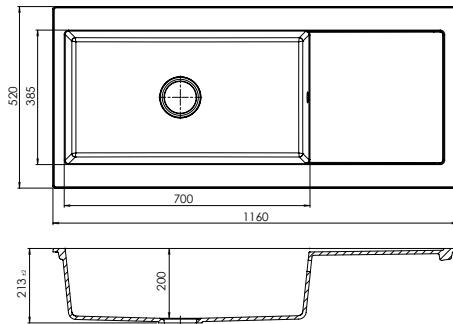

ZYZ_X213 (F)

SINK DIMENSIONS: 960x510x194mm
 BOWL DIMENSIONS: 450x390x180mm

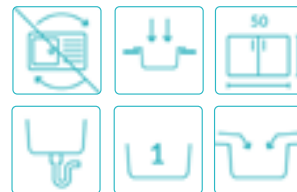
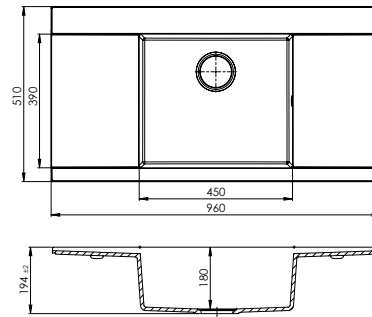

ZYZ_X653 (F)

SINK DIMENSIONS: 959x509x194mm
 BOWL DIMENSIONS: 450x390x180mm

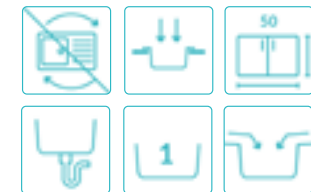
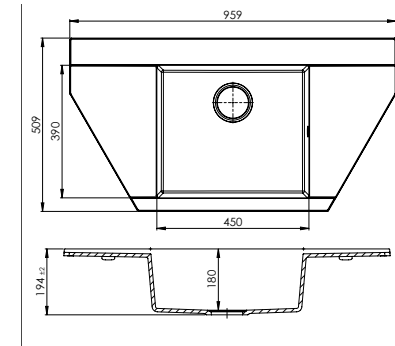

ZYZ_X70D (H)

SINK DIMENSIONS: 1160x500x223mm BOWL DIMENSIONS: 1090x360x210mm

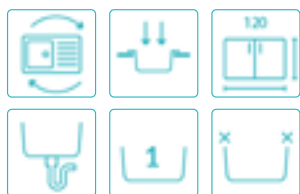
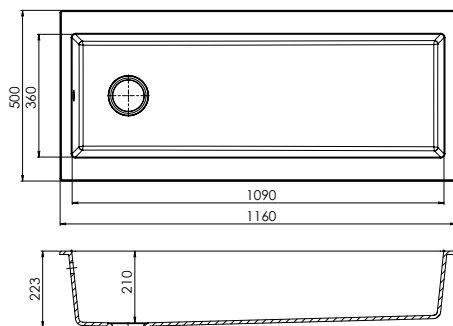
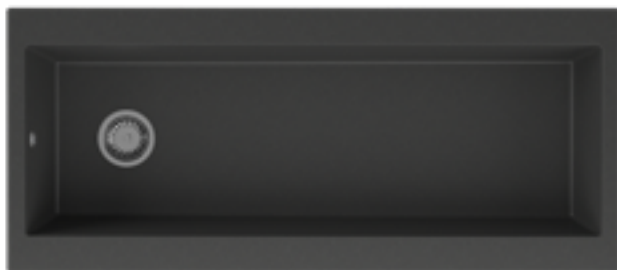

ZYZ_X913 (F)

SINK DIMENSIONS: 1200x510x215mm BOWL DIMENSIONS: 345x370x200mm
345x370x200mm

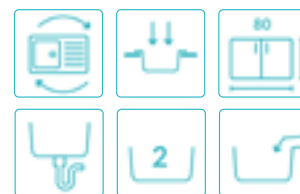
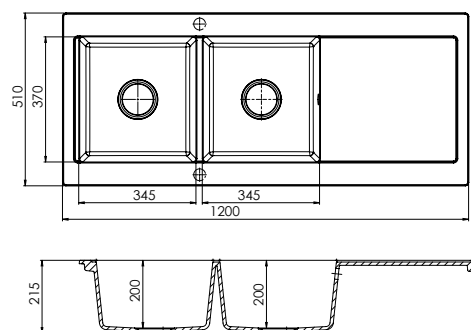



FARMHOUSE COLLECTION





SERIES **JULA**

JULA

ZYJ_X103

SINK DIMENSIONS:
613x487x185mm

BOWL DIMENSIONS:
540x420x180mm

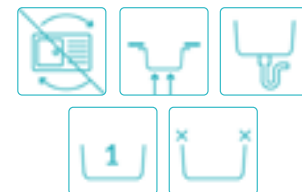
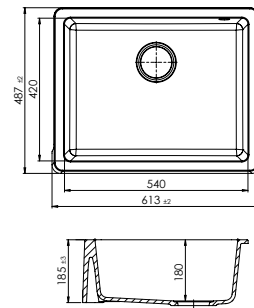



SERIES **BELLA**



BELLA

ZVN_X103

SINK DIMENSIONS:
600x495x220mm

BOWL DIMENSIONS:
525x400x206mm

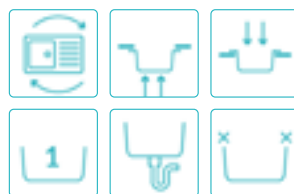
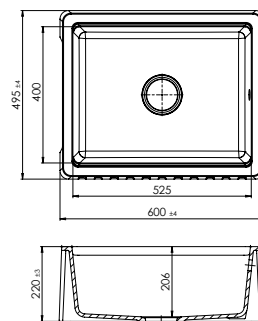

ZVN_X203

SINK DIMENSIONS:
800x515x220mm

BOWL DIMENSIONS:
357x420x206mm

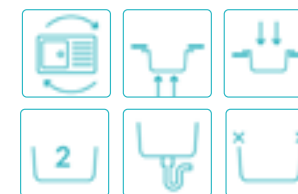
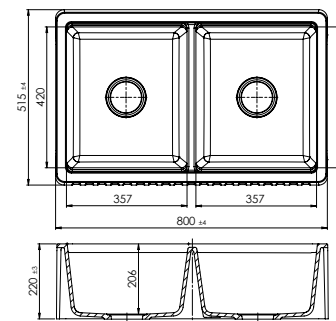



SERIES **EMMA**

ZVJ_X11A (E)

SINK DIMENSIONS: 800x630x212mm
BOWL DIMENSIONS: 500X460X190mm

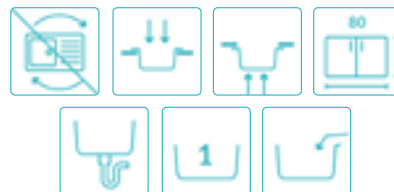
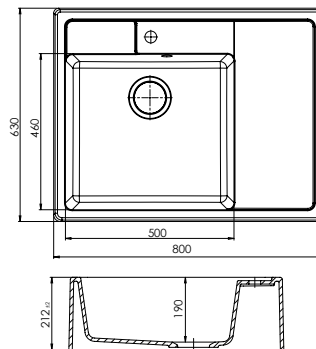

ZVJ_X203 (F)

SINK DIMENSIONS: 800x630x212mm
BOWL DIMENSIONS: 353X460X190mm

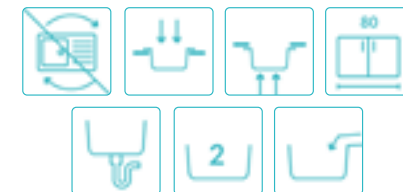
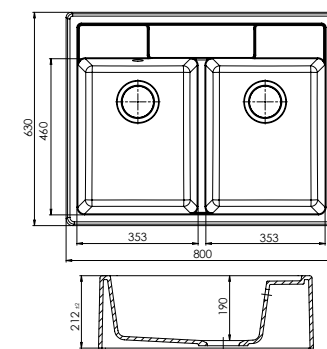



SERIES SBARRA



SBARRA

ZVZ_X703

SINK DIMENSIONS:
838x520x240mm

BOWL DIMENSIONS:
755x415x226mm

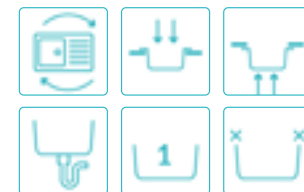
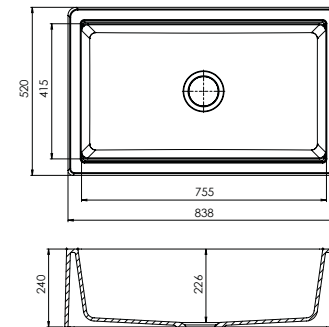

STANDARD COLLECTION





SERIES **AMARETTO**

ZVA_X11A (E)

SINK DIMENSIONS: 580x440x164mm BOWL DIMENSIONS: 340x373x150mm

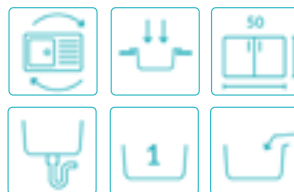
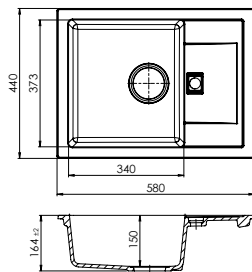
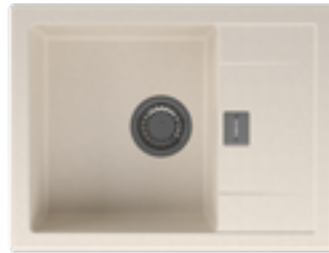

ZVA_X113 (F)

SINK DIMENSIONS: 760x440x164mm BOWL DIMENSIONS: 360x373x150mm

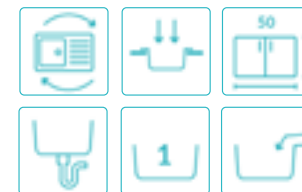
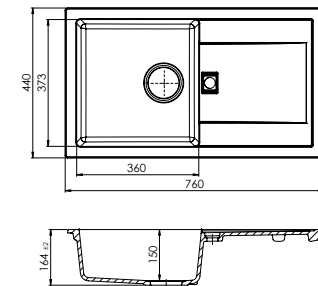



SERIES **ASTER**

ZYT_X113 (F)

SINK DIMENSIONS:
780x470x204mm

BOWL DIMENSIONS:
Ø 400x190mm

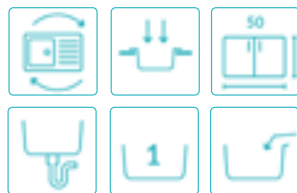
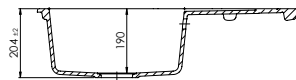
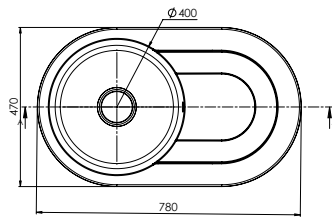

ZYT_X203 (F)

SINK DIMENSIONS:
780x470x204mm

BOWL DIMENSIONS:
390x320x190mm

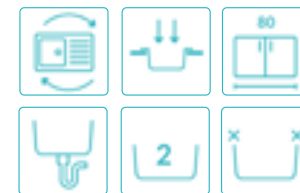
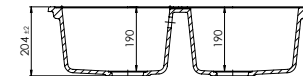
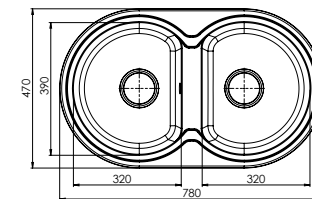



SERIES **CARO**

ZVK_X11A (E)

SINK DIMENSIONS: 595x475x172mm
BOWL DIMENSIONS: 315x395x160mm

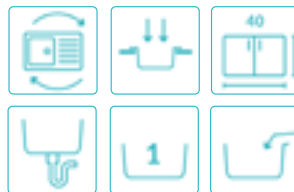
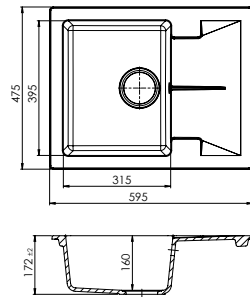

ZVK_X113 (F)

SINK DIMENSIONS: 780x480x192mm
BOWL DIMENSIONS: 400x400x180mm

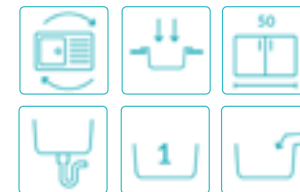
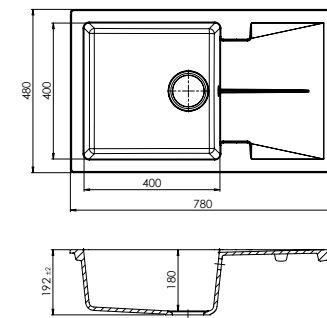



SERIES CELINE

ZYC_X203 (F)

SINK DIMENSIONS:
760x480x184mm

BOWL DIMENSIONS:
415x325x170mm

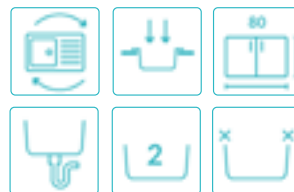
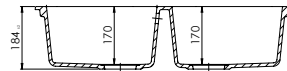
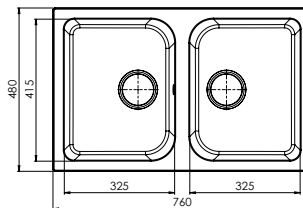

ZYC_X20B (G)

SINK DIMENSIONS:
838x559x216mm

BOWL DIMENSIONS:
420x362x202mm

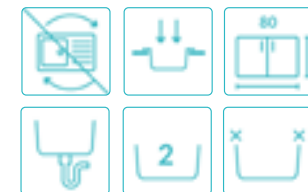
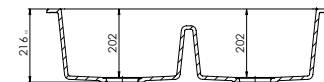
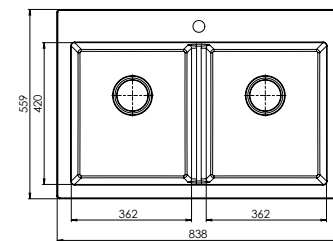



SERIES IVO

ZYI_X103 (F)

SINK DIMENSIONS:
400x500x192mm

BOWL DIMENSIONS:
340x395x180mm

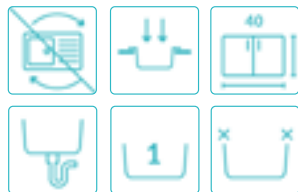
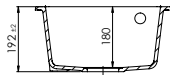
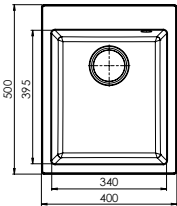

ZYI_X11A (E)

SINK DIMENSIONS:
660x440x178mm

BOWL DIMENSIONS:
340x370x162mm

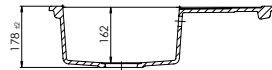
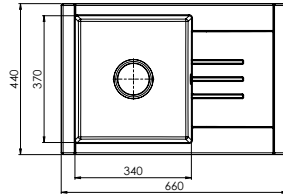

ZYI_X113 (F)

SINK DIMENSIONS:
760x440x178mm

BOWL DIMENSIONS:
340x370x162mm

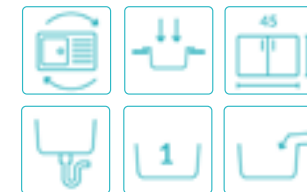
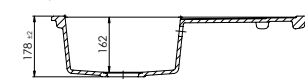
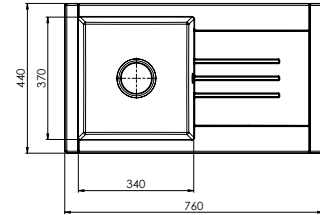



SERIES **GRACIA**

ZYG_X11A (E)

SINK DIMENSIONS:
580x440x164mm

BOWL DIMENSIONS:
340x360x150mm

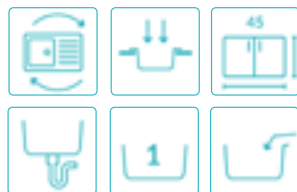
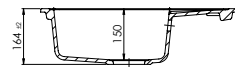
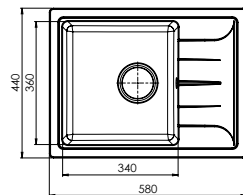

ZYG_X113 (F)

SINK DIMENSIONS:
760x440x165mm

BOWL DIMENSIONS:
340x360x151,5mm

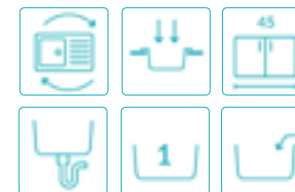
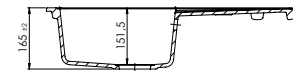
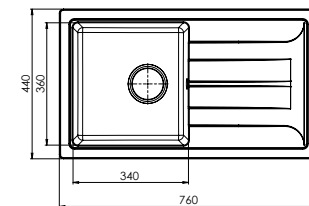



SERIES **QUADRATO**

ZYQ_X11A (E)

SINK DIMENSIONS: 640x480x174mm
 BOWL DIMENSIONS: 400x400x160mm

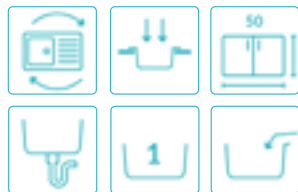
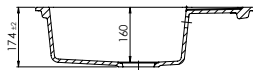
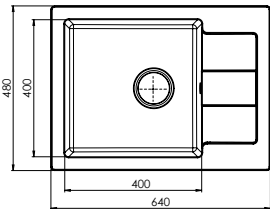

ZYQ_X113 (F)

SINK DIMENSIONS: 780x480x194mm
 BOWL DIMENSIONS: 400x400x180mm

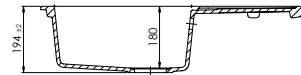
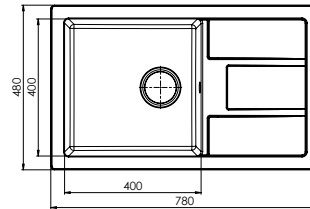

ZYQ_X653 (F)

SINK DIMENSIONS: 900x500x174mm
 BOWL DIMENSIONS: 345x430x160mm
 110x295x57mm

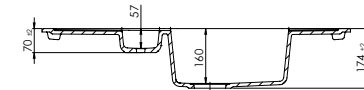
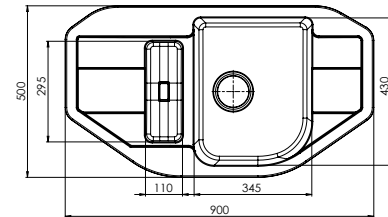



SERIES **ROSA**

ZYR_X713 (F)

SINK DIMENSIONS:
900x470x194mm

BOWL DIMENSIONS:
410x410x180mm

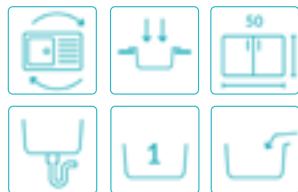
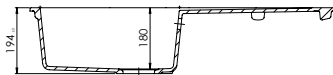
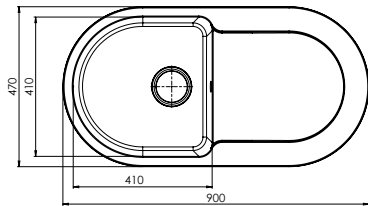

ZYR_X113 (F)

SINK DIMENSIONS:
780x440x194mm

BOWL DIMENSIONS:
350x380x180mm

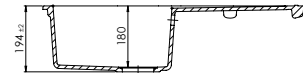
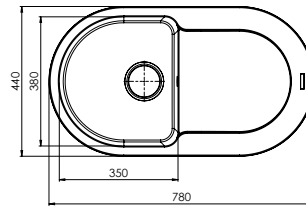

ZYR_X11A (E)

SINK DIMENSIONS:
640x480x203mm

BOWL DIMENSIONS:
380x360x190mm

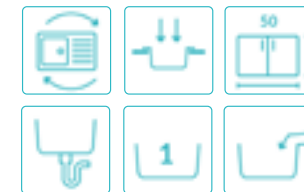
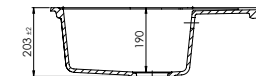
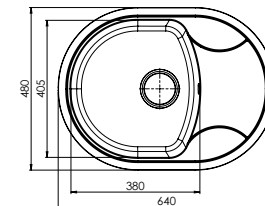



SERIES **SMART**



SMART

ZVS_X113 (F)

SINK DIMENSIONS:
670x440x164mm

BOWL DIMENSIONS:
360x380x152mm

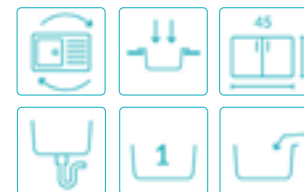
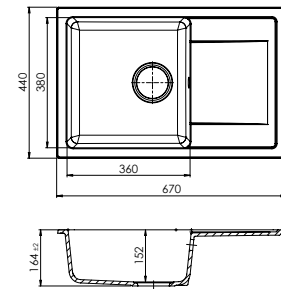



SERIES SONNO

ZYN_X11A (E)

SINK DIMENSIONS:
580x470x199mm

BOWL DIMENSIONS:
Ø 390x185mm

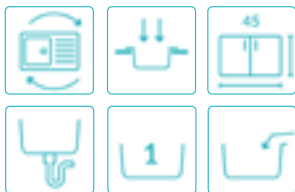
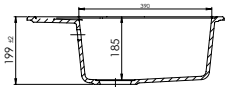
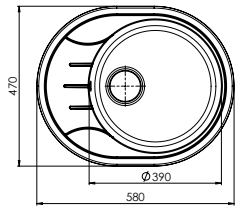

ZYN_X80B (G)

SINK DIMENSIONS:
Ø 490x184mm

BOWL DIMENSIONS:
430x370x170mm

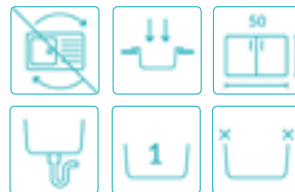
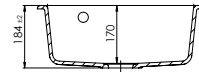
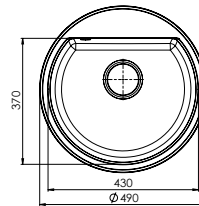

ZYN_X803 (F)

SINK DIMENSIONS:
Ø 510x194mm

BOWL DIMENSIONS:
445x380x180mm

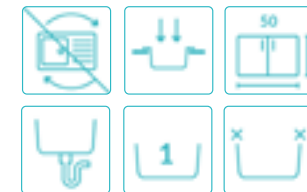
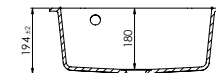
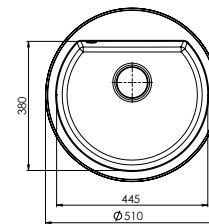

ACCESSORIES

COLLECTION





ACCESSORIES **RAILING**

ACCESSORIES

ZZRXN22A 60 CM

DIMENSIONS:
366x176x63mm

MATERIAL:
stainless
steel



ZZRXN23A 80 CM

DIMENSIONS:
366x176x63mm

MATERIAL:
stainless
steel



ZZRXN24A 100 CM

DIMENSIONS:
366x176x63mm

MATERIAL:
stainless
steel



ZZRXN10A

DIMENSIONS:
20x26x46mm

MATERIAL:
stainless steel



BLACK

ZZRXN11A

DIMENSIONS:
80x26x46mm

MATERIAL:
stainless steel



BLACK

ZZRXN13A

DIMENSIONS:
106x76x200mm

MATERIAL:
stainless steel



BLACK

ZZRXN14A

DIMENSIONS:
220x100x210mm

MATERIAL:
stainless steel



BLACK

ZZRXN15A

DIMENSIONS:
220x100x345mm

MATERIAL:
stainless
steel



BLACK

ZZRXN12A

DIMENSIONS:
306x50x160mm

MATERIAL:
stainless
steel



BLACK

ZZRXN16A

DIMENSIONS:
270x98x209mm

MATERIAL:
stainless
steel



BLACK



ACCESSORIES

KITCHEN ORGANISER

ACCESSORIES

ZZTKN01A 50 CM

DIMENSIONS:
500x216x106mm

MATERIAL:
stainless steel

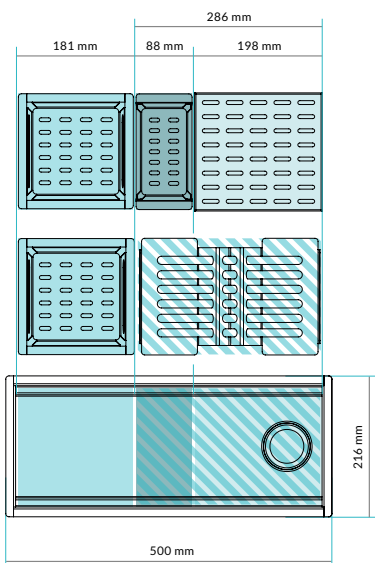
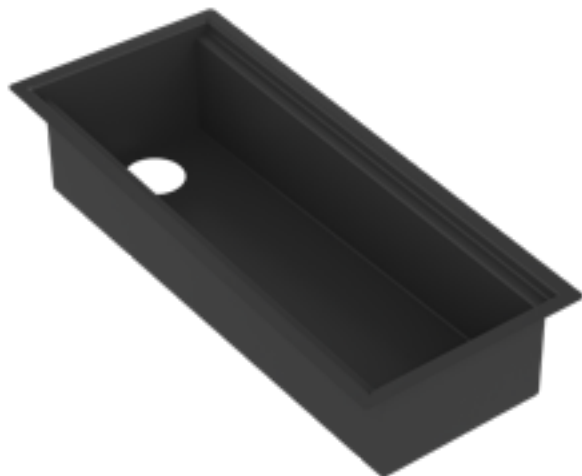

Plate drainer

DIMENSIONS:
286x185x79mm

MATERIAL:
stainless steel



BLACK

Large basket

DIMENSIONS:
181x181x80mm

MATERIAL:
stainless steel



BLACK

Cutlery drainer

DIMENSIONS:
181x88x80mm

MATERIAL:
stainless steel



BLACK

Flat drainer

DIMENSIONS:
198x183x12mm

MATERIAL:
stainless steel

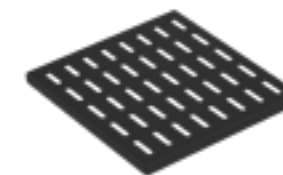

BLACK

